

인사말
Greeting

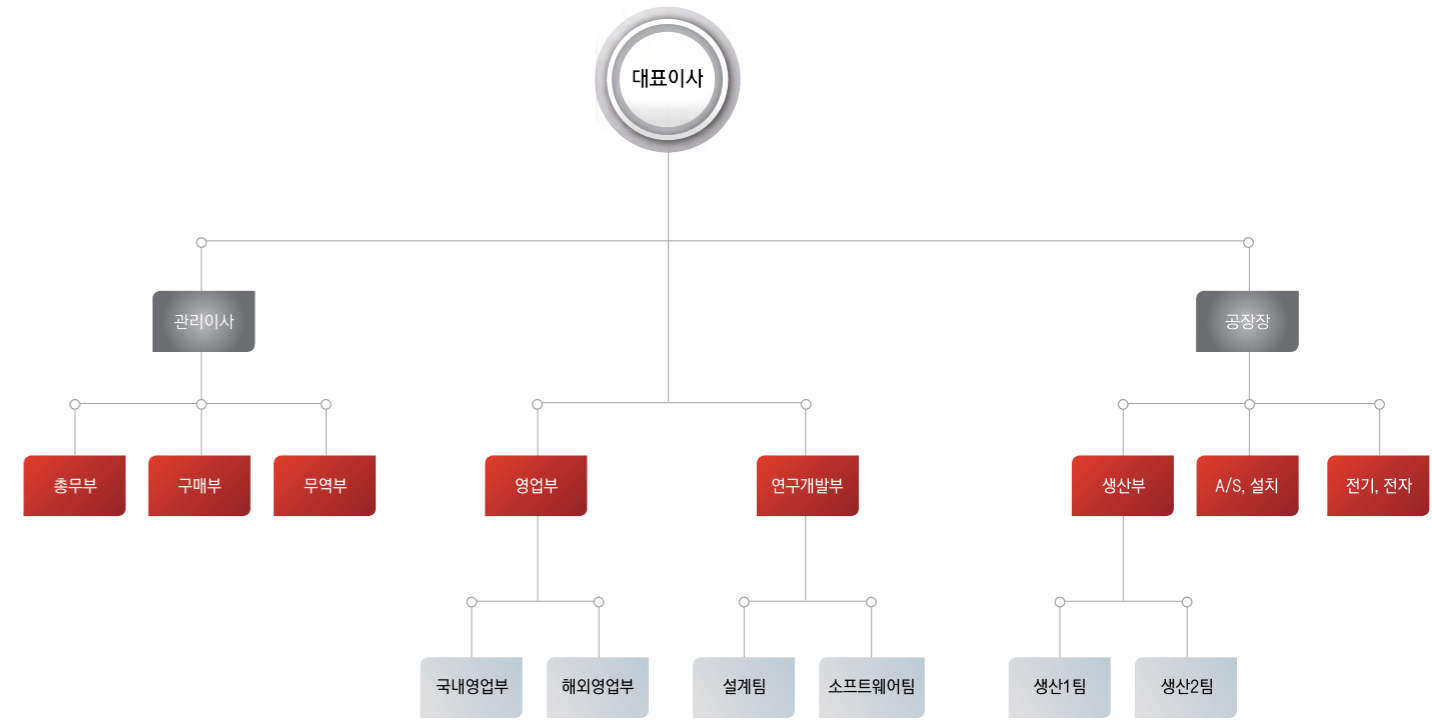

조직도
Organization



While we, KOTEC SYSTEM, Specialized in fabricating industrial machinery for the structural steel, we are lasting quite splendid achievement and endeavoring to contribute to structural steel industry with the maximum customer satisfaction.

To reach this goal calls for continuous investment in our product development to ensure that we are always able to offer the most suitable solution at peak levels of efficiency. Structural steel fabricating & processing machinery of KOTEC SYSTEM are well-known for high performance and reliability.

Customized features and dedicated service provided by KOTEC SYSTEM helps clients with guaranteed satisfaction.

KOTEC SYSTEM Co., Ltd



CERTIFICATION

CERTIFICATION

CERTIFICATION

CERTIFICATION



CE



ISO 14001



ISO 9001

Global channel



KOTEC SYSTEM will be the maker of the 21 century based on advance technology and progressive sprit.

Exhibition



SIMTOS 2014



SIMTOS 2016



WELDINGKOREA 2016



WELDINGKOREA 2018



금속산업대전 2019



WELDINGKOREA 2020

해외지사

- JAPAN** TOKYO-TO TIYODA-KU
- CHINA** Shanghai Xingyi Road
- VIETNAM** HA NOI HOANG MAI DISTRICT

해외대리점

- | | | | | | |
|----------|---------|-------------|-----------|-----------|--------------|
| China | Japan | Australia | Thailand | Singapore | Vietnam |
| Malaysia | Myanmar | Philippines | Indonesia | India | England |
| Holland | France | Canada | Russia | Turkey | Saudi Arabia |
| Iran | Algeria | Mexico | U.A.E | | |

H-BEAM PROCESSING LINE SYSTEM



• Band Sawing Machine •
DIAMOND-1300T



• Beveling Machine •
KTB-1255NL



• H-Beam Drilling Machine •
newRun13



• Band Sawing Machine •
DIAMOND-1000T



BEAM DRILLING & SAWING TANDEM LINE

BEAM DRILLING & SAWING TANDEM LINE



Spindle movement in X direction

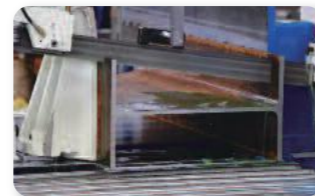
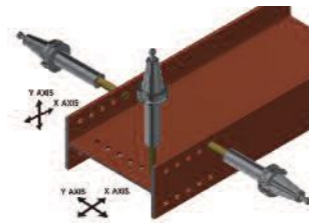

>> Features

1. Work space saving and simultaneous control of drill & cutting by one operator
2. Fast drilling with tungsten carbide drill
3. Spindle movement in X direction (Beam length direction)
4. Easy data input and human interface
5. Fast and precise material feeding by servo system - Carriage type
6. Automatic cutting of both angles (-45°~+60°)

>> Specifications

MODEL		newRun 13DX TANDEM LINE	newRun 10DX TANDEM LINE
DRILLING			
Processing capacity	H	150×75 ~ 1,300×600mm	125×60 ~ 1,000×500mm
	П	150×75 ~ 380×100mm	125×65 ~ 380×100mm
	L	150×150 ~ 300×300mm	125×125 ~ 300×300mm
	□	150×150 ~ 600×600mm	125×125 ~ 500×500mm
Carriage stroke		13m (Standard)	
Drill bit capacity		Oil HOLE, Tungsten Carbide Drill : Ø12~Ø40	
Dimension(W×L×H)		5,768×1,950×3,500mm(without Carriage)	5,000×1,550×3,200mm(without Carriage)
Weight		12,500kg	9,400kg
BAND SAWING			
Capacity	90°	1,300×600mm	1,000×600mm
	-45°	800×600mm	650×600mm
	+60°	500×600mm	400×600mm
Blade size(W×T×L)		67×1,6×9,980mm	54×1,6×8,800mm
Dimension(W×L×H)		5,400×2,560×2,600mm	4,800×2,250×2,550mm
Weight		7,850kg	6,850kg

*NOTE : Specifications are subject to change for quality improvement.



>> Features

1. Work space saving and simultaneous control of drill & cutting by one operator
2. Fast drilling with tungsten carbide drill
3. Spindle movement in X direction (Beam length direction)
4. Easy data input and human interface
5. Fast and precise material feeding by servo system - Carriage type
6. Automatic cutting of both angles (-45°~+60°)

>> Specifications

MODEL		newRun 7DX TANDEM LINE
DRILLING		
Processing capacity	H	100×50 ~ 700×400mm
	П	75×40 ~ 380×100mm
	L	75×75 ~ 300×300mm
	□	75×75 ~ 400×400mm
Carriage stroke		13m (Standard)
Drill bit capacity		Oil HOLE, Tungsten Carbide Drill : Ø12~Ø32
Dimension(W×L×H)		4,250×1,680×2,870mm(without Carriage)
Weight		7,700kg
BAND SAWING		
Capacity	90°	700×400mm
	-45°	450×400mm
	+60°	250×400mm
Blade size(W×T×L)		54×1,6×6,250mm
Dimension(W×L×H)		2,850×1,850×2,400mm
Weight		3,690kg

*NOTE : Specifications are subject to change for quality improvement.

Drilling (ATC)



Bandsawing

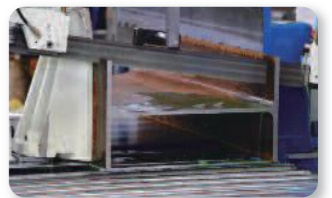

H-BEAM DRILLING MACHINE

H-BEAM DRILLING MACHINE



>> Features

1. Max. H-BEAM Size 1,300 x 600mm
2. Fast drilling with tungsten carbide drill
3. Spindle movement in X direction (Beam length direction)
4. Easy data input and human interface
5. Fast and precise material feeding by servo system - Carriage type

Spindle movement in X direction

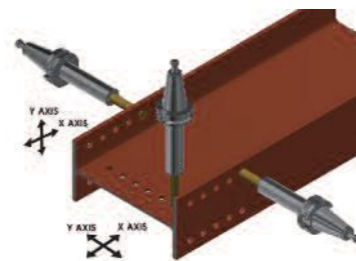

>> Specifications

MODEL	newRun 13DX		newRun 10DX		
Processing capacity	H	150×75 ~ 1,300×600mm	150×75 ~ 1,300×600mm	150×75 ~ 1,000×500mm	125×60 ~ 1,000×500mm
	Π	150×75 ~ 380×100mm	150×75 ~ 380×100mm	150×75 ~ 380×100mm	150×65 ~ 380×100mm
	L	150×150 ~ 300×300mm	150×150 ~ 300×300mm	150×150 ~ 300×300mm	125×125 ~ 300×300mm
	□	N/A	150×150 ~ 600×600mm	N/A	125×125 ~ 500×500mm
Carriage stroke	7m (Standard)	13m (Standard)	7m (Standard)	13m (Standard)	
Drill bit capacity	Oil HOLE, Tungsten Carbide Drill : Ø12~Ø40				
Dimension (W×L×H)	5,768×1,950×3,500mm(without Carriage)		5,000×1,550×3,200mm(without Carriage)		
Weight	12,500kg		9,400kg		

*NOTE : Specifications are subject to change for quality improvement.

>> Features

1. Max. H-BEAM Size 700 x 400mm
2. Fast drilling with tungsten carbide drill
3. Spindle movement in X direction (Beam length direction)
4. Easy data input and human interface
5. Fast and precise material feeding by servo system - Carriage type

Spindle movement in X direction

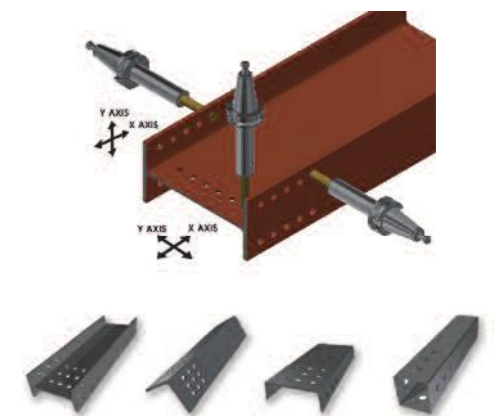

>> Specifications

MODEL	newRun 7DX	
Processing capacity	H	100×50 ~ 700×400mm
	Π	75×40 ~ 380×100mm
	L	75×75 ~ 300×300mm
	□	75×75 ~ 400×400mm
Carriage stroke	13m (Standard)	
Drill bit capacity	Oil HOLE, Tungsten Carbide Drill : Ø12~Ø32	
Dimension (W×L×H)	4,250×1,680×2,870mm(without Carriage)	
Weight	7,700kg	

*NOTE : Specifications are subject to change for quality improvement.

MULTI BEAM DRILLING MACHINE

MULTI BEAM DRILLING MACHINE



>> Features

1. Fast drilling with tungsten carbide drill
2. Various section steel drilling possible - 3 axis
3. Easy data input and human interface
4. Fast and precise material feeding by servo system - Carriage type

Drilling (ATC)



>> Specifications

MODEL	newRun 13		newRun 10		
Processing capacity	H	150×75 ~ 1,300×600mm	150×75 ~ 1,300×600mm	150×75 ~ 1,000×500mm	125×60 ~ 1,000×500mm
	П	150×75 ~ 380×100mm	150×75 ~ 380×100mm	150×75 ~ 380×100mm	150×65 ~ 380×100mm
	L	150×150 ~ 300×300mm	150×150 ~ 300×300mm	150×150 ~ 300×300mm	125×125 ~ 300×300mm
	□	N/A	150×150 ~ 600×600mm	N/A	125×125 ~ 500×500mm
Carriage stroke	7m (Standard)	13m (Standard)	7m (Standard)	13m (Standard)	
Drill bit capacity	Oil HOLE, Tungsten Carbide Drill : Ø12~Ø40				
Dimension(W×L×H)	5,768×1,950×3,500mm(without Carriage)		5,000×1,550×3,200mm(without Carriage)		
Weight	12,500kg		9,400kg		

*NOTE : Specifications are subject to change for quality improvement.

>> Features

1. Fast drilling with tungsten carbide drill
2. Various section steel drilling possible - 3 axis
3. Easy data input and human interface
4. Fast and precise material feeding by servo system - Carriage type

>> Specifications

MODEL	newRun 7	
Processing capacity	H	100×50 ~ 700×400mm
	П	75×40 ~ 380×100mm
	L	75×75 ~ 300×300mm
	□	75×75 ~ 400×400mm
Carriage stroke	13m (Standard)	
Drill bit capacity	Oil HOLE, Tungsten Carbide Drill : Ø12~Ø32	
Dimension(W×L×H)	4,250×1,680×2,870mm(without Carriage)	
Weight	7,700kg	

*NOTE : Specifications are subject to change for quality improvement.

MULTI BEAM DRILLING & SAWING MACHINE

H-BEAM BEVELING MACHINE



Drilling (ATC)

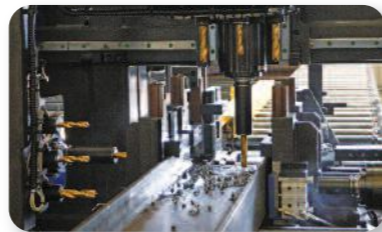

Cutting (Bandsaw)

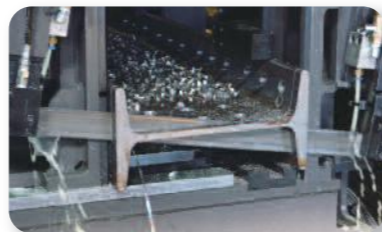

>> Features

1. Various section steel drilling possible - 3 axis
2. Work space saving and simultaneous control of drill & cutting by one operator
3. High-speed hole processing by a high-powered motor
4. Bandsaw cutting feeding by servo motor : Fast cutting
5. Fast and precise material feeding by servo system - Carriage type



>> Specifications

MODEL	newRun 5	
Processing capacity	H	100×50 ~ 500×300mm
	П	75×40 ~ 380×100mm
	L	50×50 ~ 300×300mm
	□	50×50 ~ 300×300mm
Carriage stroke	13m (Standard)	
Drill bit capacity	Oil HOLE, Tungsten Carbide Drill : Ø12~Ø32	
Sawing capacity	500×300mm	
Blade size(W×L×L)	41×1,3×6,600mm	
Dimension(W×L×H)	4,300×1,950×2,950mm(without Carriage)	
Weight	7,600kg	

*NOTE : Specifications are subject to change for quality improvement.

>> Features

1. Simultaneous operations - facing, scallop, bevel
2. Automatic continuous operation
3. Sturdy fixation with hydraulic vise

>> Specifications

MODEL	KTB-1555NL	KTB-1255NL	
Processing capacity	H	200~1,500mm	200~1,200mm
	B		100~600mm
	T		6~55mm
	L		Min. 400mm
	C		Max. 55mm
	S		-30~300mm
	R2		R35
N		Max. 50mm	
Cutting head motor	2EA		
Dimension(W×L×H)	3,227×2,281×2,767mm	2,250×3,170×2,610mm	
Weight	9,000kg	8,500kg	

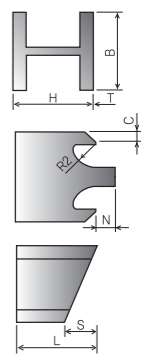

*NOTE : Specifications are subject to change for quality improvement.

BAND SAWING MACHINE

BAND SAWING MACHINE



>> Features

1. Faster cutting speed control by servo system
2. Max 45° miter cutting - Angle digital control
3. LM(Linear Motion) guide for stable saw blade feed

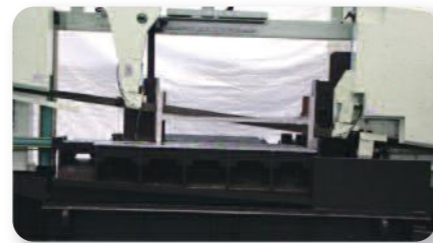

>> Features

1. Max 45° miter cutting - Angle digital control
2. LM(Linear Motion) guide for stable saw blade feed
3. Automatic cutting speed control system & cutting end point

>> Specifications

MODEL	DIAMOND-1300TS				DIAMOND-1000TS				DIAMOND-800TS				
	Round(Ø)		Ø600		Ø600		Ø600		Ø400		Ø400		
Capacity	Square(W×H)	90°	1,300×600mm	45°	750×600mm	90°	1,000×600mm	45°	600×600mm	90°	800×400mm	45°	480×400mm
	Bundle(W×H)		1,300×430mm		750×430mm		1,000×430mm		600×430mm		800×400mm		480×400mm
	Blade size(W×T×L)	67×1.6×9,700mm				67×1.6×8,370mm				54×1.6×8,000mm			
Feeding stroke	320mm				320mm				320mm				
Dimension(W×L×H)	5,400×2,560×2,600mm				4,800×2,250×2,550mm				4,100×1,900×2,800mm				
Weight	7,850kg				6,850kg				5,500kg				

*NOTE : Specifications are subject to change for quality improvement.

>> Specifications

MODEL	DIAMOND-1300T				DIAMOND-1000T				DIAMOND-700T				
	Round(Ø)		Ø600		Ø600		Ø600		Ø400		Ø380		
Capacity	Square(W×H)	90°	1,300×600mm	45°	750×600mm	90°	1,000×600mm	45°	600×600mm	90°	700×400mm	45°	380×400mm
	Bundle(W×H)		1,300×430mm		750×430mm		1,000×430mm		600×430mm		700×300mm		380×300mm
	Blade speed	20~90m/min				20~90m/min				20~90m/min			
Saw blade	Blade size(W×T×L)	67×1.6×9,700mm				54×1.6×8,800mm				41×1.3×5,790mm			
	Feeding stroke	320mm				320mm				-			
Dimension(W×L×H)	5,400×2,560×2,600mm				4,800×2,250×2,550mm				2,850×1,850×2,400mm				
Weight	7,850kg				6,850kg				3,690kg				

*NOTE : Specifications are subject to change for quality improvement.

BAND SAWING MACHINE

BAND SAWING MACHINE



>> Features

1. Max -45° ~ +60° miter cutting - Angle digital control
2. LM(Linear Motion) guide for stable saw blade feed
3. Faster cutting speed control by servo system

>> Specifications

MODEL		DIAMOND-1300DT	DIAMOND-1000DT	DIAMOND-700DT
Capacity	90°	1,300×600mm	1,000×600mm	700×400mm
	-45°	800×600mm	650×600mm	450×400mm
	+60°	500×600mm	400×600mm	250×400mm
Blade size(W×T×L)		67×1.6×9,980mm	54×1.6×8,800mm	41×1.3×6,250mm
Dimension(W×L×H)		5,400×2,560×2,600mm	4,800×2,250×2,550mm	2,850×1,850×2,400mm
Weight		7,850kg	6,850kg	3,690kg

*NOTE : Specifications are subject to change for quality improvement.

>> Features

1. Specialized design for easy cutting of bundles and raw materials
2. Automatic cutting speed control system & cutting end point
3. LM(Linear Motion) guide for stable saw blade feed

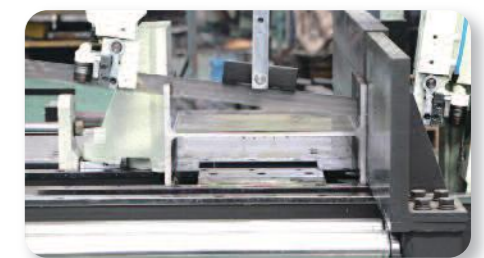

>> Specifications

MODEL		DIAMOND-10A	DIAMOND-7A
Capacity	Bundle(W×H)	1,000×1,000mm	700×555mm
Saw blade	Blade speed	75m/min	
	Blade size(W×T×L)	67×1.6×10,000mm	54×1.6×7,150mm
Dimension(W×L×H)		4,800×2,250×2,550mm	3,475×2,255×2,641mm
Weight		6,850kg	7,000kg

*NOTE : Specifications are subject to change for quality improvement.

PLATE BEVELING MACHINE

PORTABLE PLATE BEVELING MACHINE



>> Features

- 1.Upper, lower cutter beveling at the same time
- 2.Bevel angle adjustable by digital control
- 3.Tungsten carbide cutting insert - changeable

>> Specifications

MODEL	PB-2000K	PB-3000K	PB-5000K
Max. Plate length for beveling	2,000mm	3,000mm	5,000mm
Capacity	$\theta 1$	0~70°	
	$\theta 2$	0~60°	
	T	Max. 60mm	
	C1	Max. 18mm (when $\theta=45^\circ$)	
	C2	Max. 18mm (when $\theta=45^\circ$)	
Cutting speed	100 ~ 750mm/min		
Clamp	12 set	18 set	21 set
Cutting head motor	2EA		
Dimension (L×W×H)	3,850×1,710×1,950mm	4,850×1,710×1,950mm	8,630×1,870×2,540mm
Weight	6,500kg	8,500kg	16,500kg

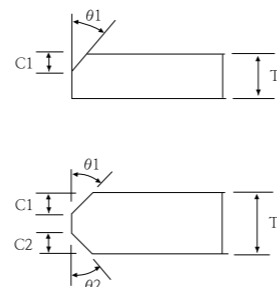

Work table : Option

>> Features

- 1.Portable type beveling machine
- 2.Self driving system to bevel a big plate
- 3.Tungsten carbide cutting insert - changeable

>> Specifications

MODEL	SMB-20C	
Cutting Speed	50Hz	280mm/min
	60Hz	330mm/min
Cutter Rotation	50Hz	250 RPM
	60Hz	300 RPM
Option	Stainless, Aluminum, Table, Double inverter Upper / Lower bevelling	
Weight	260kg	

*OPTION : Inverter motor for stainless steel beveling

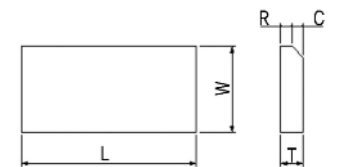

	SMB-20C
L	200mm~Unlimited
W	150mm~Unlimited
T	4~40mm
C	Max. 20mm
Beveling angle	35, 45 degrees

PLATE SUPER DRILLING MACHINE

PLATE DRILLING MACHINE

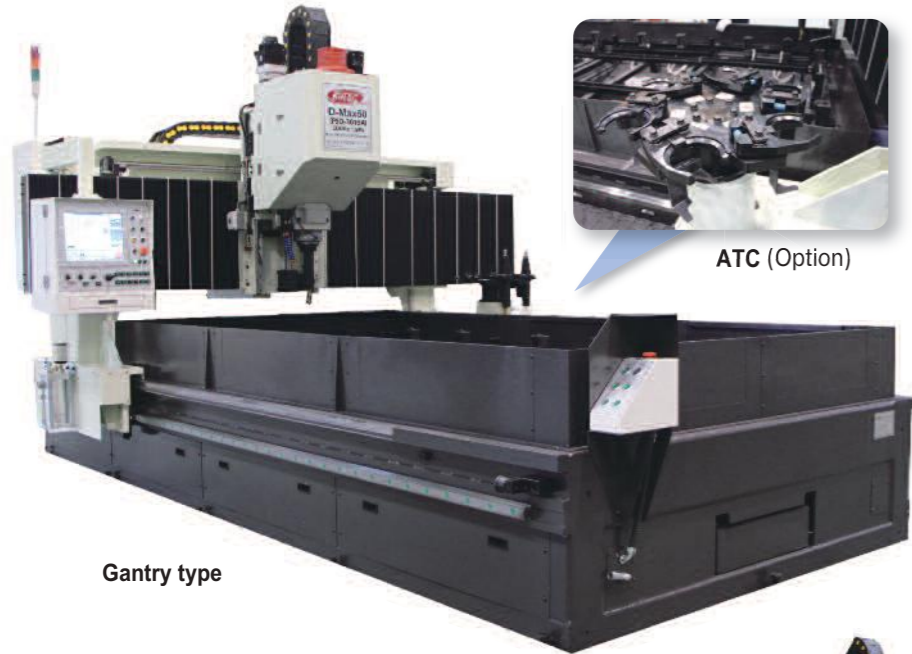

Gantry type



Semi gantry type

>> Features

1. Carbide drill can be used with high-powered motor
2. CAD file interface, DXF file
3. MS windows based OS, file upload with USB memory
4. ATC(Auto Tool change) optional

>> Specifications

MODEL	D-MAX50				
Travelling type	Semi gantry type	Gantry type			
Max. processing capacity	600×3,000mm	2,000×1,000mm	3,000×1,000mm	4,000×1,500mm	6,300×2,500mm
Max. drill bit capacity	Ø40	Carbide drill : Ø50 / Taper drill : Ø50			
Processing data entry	CAD file interface(18 patterns)				
Tool change	Manual type / ATC(Auto Tool Change : option)-6sets				
Work clamp stroke	85mm(20~105mm)				
Work clamp	12set	12set	12set	16set	20set
Work point	4 point				
Dimension(W×L×H)	2,700×5,750(6,950)×2,500mm	2,250×3,360(4,562)×2,750mm	2,250×4,400(5,600)×2,750mm	3,000×5,750(6,400)×2,750mm	4,250×8,050(8,550)×2,750mm
Weight	4,600kg	5,400kg	6,200kg	8,500kg	11,500kg

*NOTE : Specifications are subject to change for quality improvement.

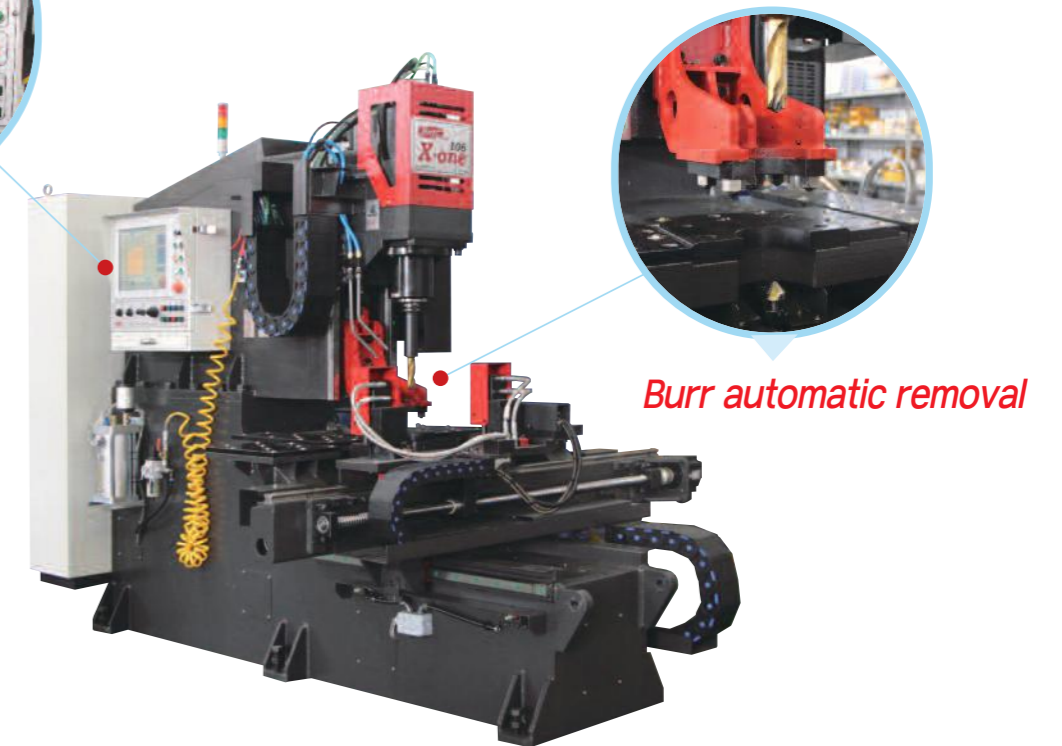

Burr automatic removal

>> Features

1. Simultaneous automatic removal of burr on the back of the hole after drilling
2. Carbide drill can be used with high-powered motor
3. CAD file interface, DXF file
4. MS windows based OS, file upload with USB memory

>> Specifications

MODEL	X-One 106
Max. processing capacity	1,000×600mm 40t
Max. drill bit capacity	Carbide drill : Ø32
Processing data entry	CAD file interface (18 patterns)
Work clamp	2Set (Hydraulic)
Material pusher	1Set (Hydraulic)
Dimension(W×L×H)	2,000×2,550×2,050

PLATE PUNCHING MACHINE

ANGLE PUNCHING MACHINE



Model : KTPK-100



Model : KTPK-100AT

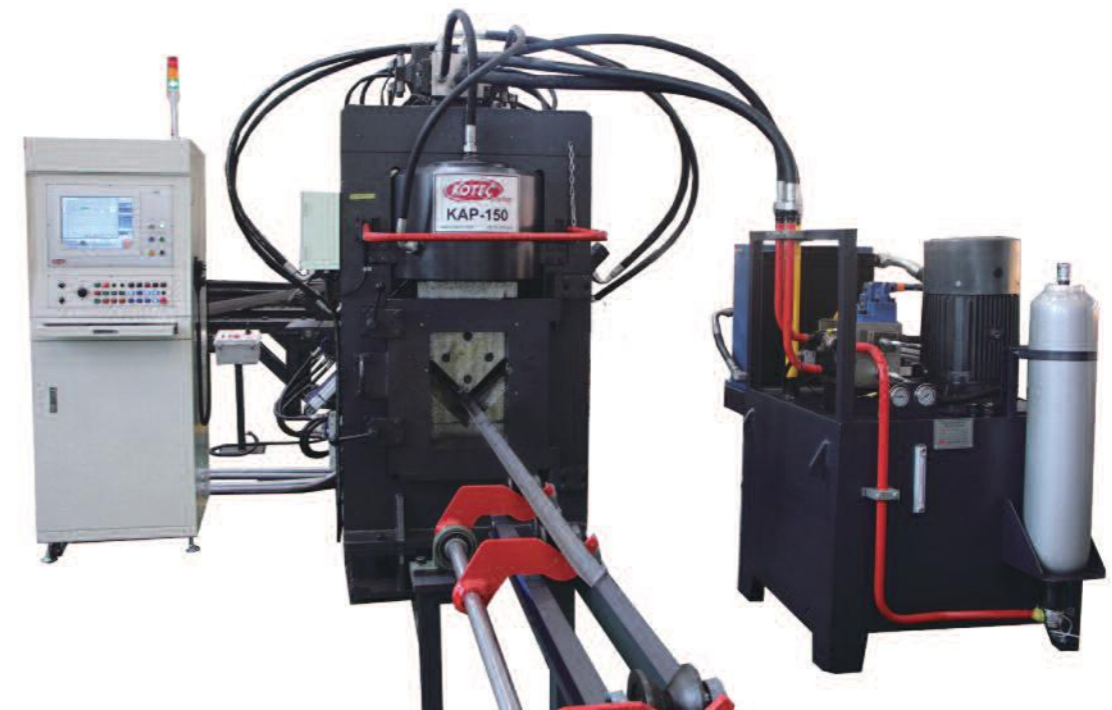

>> Features

1. Max plate size 1,000 × 500 × 25t
2. Powerful punching action with a big cylinder
3. CAD file interface, DXF file
4. MS windows based OS, file upload with USB memory

>> Specifications

MODEL	KTPK-100	KTPK-100AT
Max. pressing power	100ton	
Max. Processing capacity	Min. 100×100×6t / Max. 1,000×500×25t(L×W×T)	
Max. Punching capacity	25t×Ø32	
Tool change	N/A	3set (2punches+1marking tool or 3punches)
Processing data entry	CAD file interface (18 patterns)	
Dimension(W×L×H)	2,200×2,900×2,000mm	2,200×2,800×1,900mm
Weight	4,500kg	5,400kg

*NOTE : Specifications are subject to change for quality improvement.

>> Features

1. Auto tool change system is available for various holes processing
2. Automatic processing of Marking, punching & shearing by hydraulic system
3. Fast and precise material feeding by servo system - Carriage type
4. Angle auto-in/out
5. Window OS system for easy data load

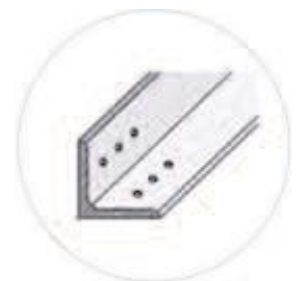

>> Specifications

MODEL	KAP-150A	KAP-120A
Max. Processing power	100Ton	60Ton
Max. Processing capacity	50mm×50mm×4t ~ 150mm×150mm×15t	40mm×40mm×3t ~ 125mm×125mm×10t
Max. Punching capacity	Max. Ø26×15t	Max. Ø26×10t
Processing data entry	Common patterns available	
Tool change	ATC(Auto tool change) 3 set per axis	ATC(Auto tool change) 2 set per axis
Shearing pressing Power	Power 220ton(Single cutting type)	Power 98ton(Single cutting type)
Shearing capacity	Min. 50mm×50mm×4t~ Max. 150mm×150mm×15t	Min. 40mm×40mm×3t~ Max. 125mm×125mm×10t
In & out feeding & Supply type(Optional)	IN : Automatic(Chain&Block Type) & Arm Supply Type Out : Automatic(Cylinder&Arm Type)	
Dimension(W×L×H)	1,680×2,600×2,150mm	1,680×2,300×2,150mm
Weight	9,100kg	7,500kg
Option	Marking system, Auto nesting program	

*NOTE : Specifications are subject to change for quality improvement.

PLATE DRILLING MACHINE

PLATE DRILLING & CUTTING MACHINE



Drill + cutting all-in-one

>> Features

1. Carbide drill can be used with high-powered motor
2. ATC(Auto Tool Change) / Multi-production in small space
3. Can be installed on the same rail with the plasma cutting machine
4. MS windows based OS, file upload with USB memory
5. Auto nesting program

>> Features

1. ATC(Auto Tool Change) / Multi-production in small space (Drill + cutting)
2. Carbide drill can be used with high-powered motor
3. Fast cutting, no preheating necessary
4. Auto nesting program
5. MS windows based OS, file upload with USB memory



ATC(Auto Tool Change System)



Drilling



ATC(Auto Tool Change System)

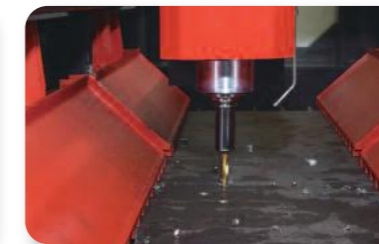

Drilling



Plasma cutting

>> Specifications

MODEL	Twin-X (드릴전용)
Machine structure	Gantry traveling
Controller	CNC
Max. processing capacity (W×T)	3,000×45mm (Length can be customized)
Max. drill bit capacity	Tungsten carbide drill (oil hole type) : Ø12~Ø40mm
Drill Spindle motor	Built-in spindle motor (BT-50)
Work Clamp	4sets
Work Table	Wood support
Dimension (W×L×H)	5,850×2,300×2,550mm (Machine)
Weight	7,100kg

*NOTE : Specifications are subject to change for quality improvement.

>> Specifications

MODEL	Twin-X
Machine structure	Gantry travelling
Controller	CNC
Max. processing capacity (W×T)	3,000×45mm (Length can be customized)
Max. drill bit capacity	Tungsten carbide drill (oil hole type) : Ø12~Ø40mm
Drill Spindle motor	Built-in spindle motor (BT-50)
Work Clamp	4sets
Work Table	Water table with Brass Pin & Grating
Dimension (W×L×H)	5,850×2,300×2,550mm (Machine)
Weight	7,100kg

*NOTE : Specifications are subject to change for quality improvement.

HIGH PRECISION PLASMA CUTTING MACHINE

HIGH PRECISION PLASMA CUTTING MACHINE

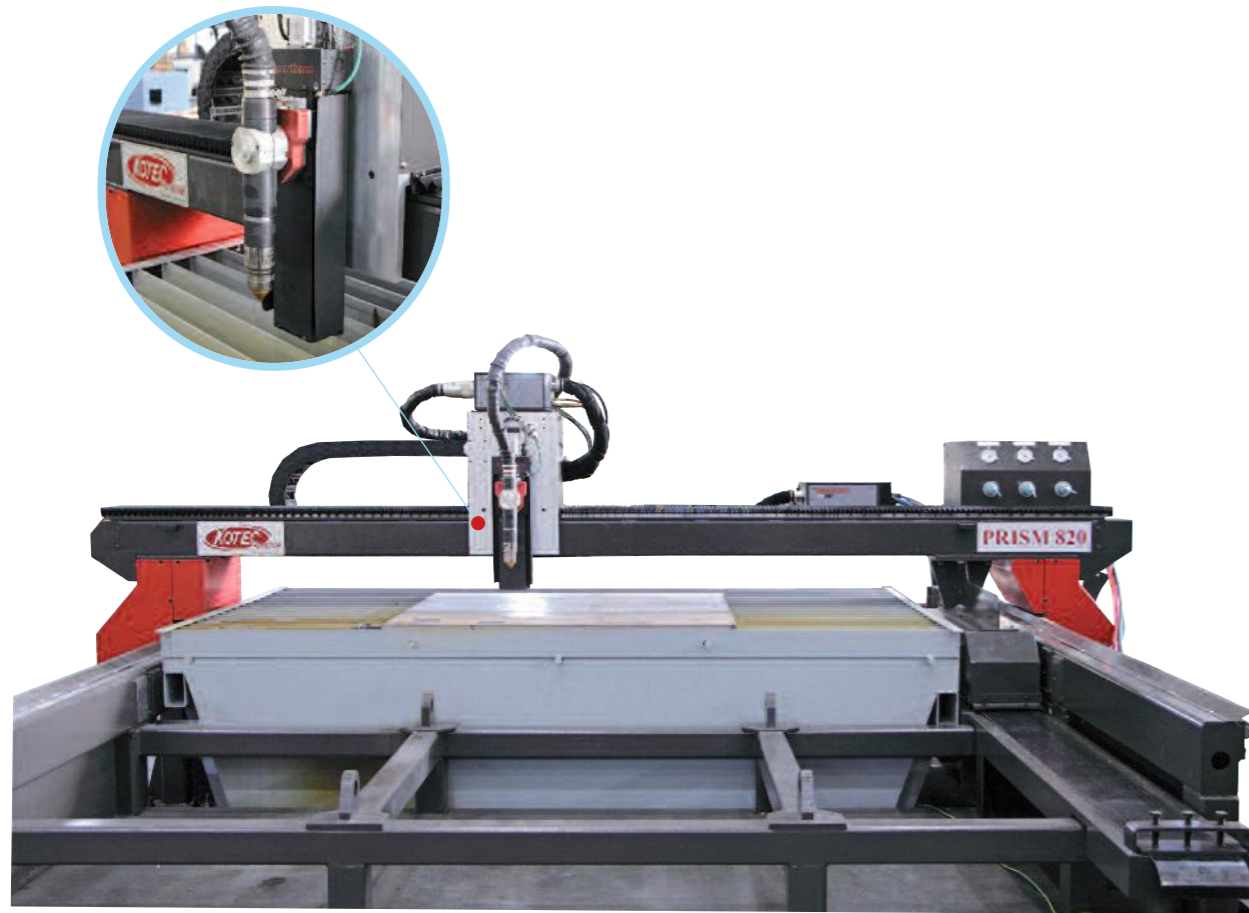

>> Features

Equipped with true hole function (Precision cutting)

>> Specifications

MODEL	PRISM-820
Max. processing capacity(W×T)	2,700×6,300mm (Changeable)
Driving speed	12,000mm/min (Max. 18,000mm/min)
Machine structure	Gantry traveling
Controller	EDGE connect (Hypertherm)
Power Supply	Plasma : 380V / 3P / 50Hz or 60Hz

*NOTE : Specifications are subject to change for quality improvement.

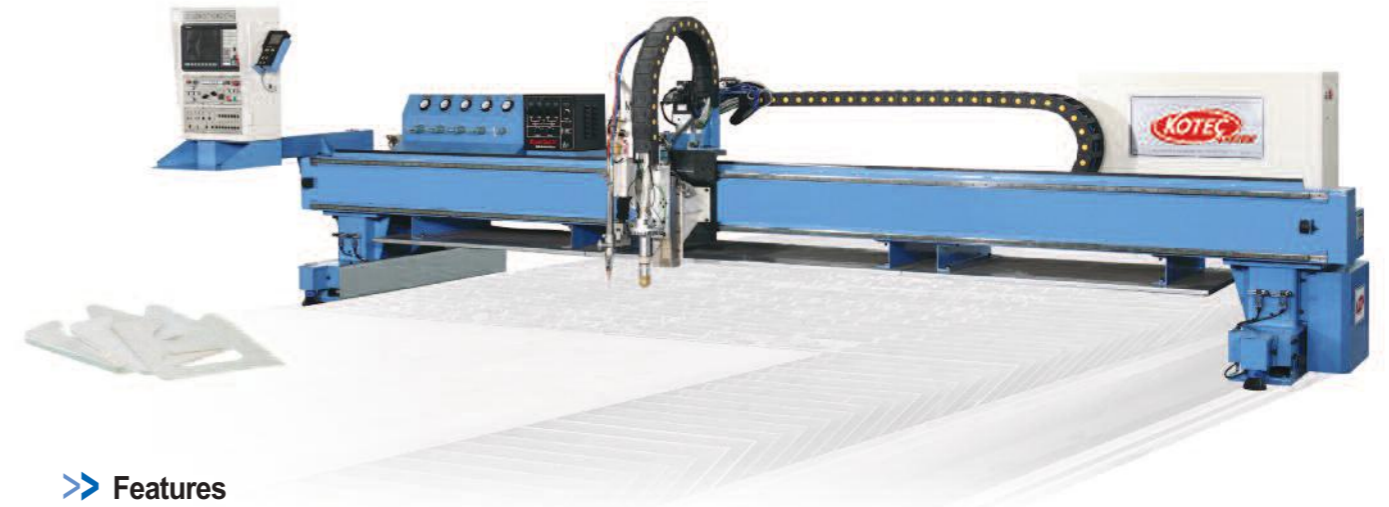

>> Features

1. High quality cutting equipped with Hypertherm Plasma Power supply
2. Additional marking, gas cutting torch available
3. Nesting software (optional)

>> Plasma Power Supply

MODEL	XPR 170	XPR 300
Mild steel (mm)		
Production-pierce	(Argon available) 40 (Standard) 35	(Argon available) 50 (Standard) 45
Severance-edge starts	60	80
Stainless steel (mm)		
Production-pierce	22	38
Severance-edge starts	38	75
Aluminum (mm)		
Production-pierce	25	38
Severance-edge starts	38	50



>> Specifications

MODEL	KTP-320	KTP-420	KTP-520	KTP-640
Machine structure	Gantry travelling			
Controller	CNC			
Rapid speed	12,000mm/min(Max. 18,000mm/min)			
Machine width	5,030mm	6,030mm	7,030mm	8,200mm
Rail width	4,050mm	5,050mm	6,050mm	7,200mm
Effective cutting width	3,200mm	4,200mm	5,200mm	6,400mm
Power supply	Plasma : 380V / 3P / 50Hz or 60Hz Controller : 220V / 3P / 50Hz or 60Hz / 5KVA(Unchangeable)			

*NOTE : Specifications are subject to change for quality improvement.

GAS CUTTING MACHINE

SHOT BLAST MACHINE

>> Features

1. All or individual torch Up/Down control
2. User specific cutting torch & marking torch available
3. Nesting software (optional)



>> Specifications

MODEL	KTG-320	KTG-420	KTG-520	KTG-640
Machine structure	Gantry travelling			
Controller	CNC			
Rapid speed	12,000mm/min(Max. 18,000mm/min)			
Machine width	5,030mm	6,030mm	7,030mm	8,200mm
Rail width	4,050mm	5,050mm	6,050mm	7,200mm
Effective cutting width	3,200mm	4,200mm	5,000mm	6,400mm
Power supply	220V / 3P / 50Hz or 60Hz / 5KVA			

*NOTE : Specifications are subject to change for quality improvement.



GAS & PLASMA CUTTING MACHINE



>> Specifications

MODEL	KTPG-320	KTPG-420	KTPG-520	KTPG-640
Machine structure	Gantry travelling			
Controller	CNC			
Rapid speed	12,000mm/min(Max. 18,000mm/min)			
Machine width	5,030mm	6,030mm	7,030mm	8,200mm
Rail width	4,050mm	5,050mm	6,050mm	7,200mm
Effective cutting width	3,200mm	4,200mm	5,000mm	6,400mm
Power supply	Plasma : 380V / 3P / 50Hz or 60Hz Controller : 220V / 3P / 50Hz or 60Hz / 5KVA(Unchangeable)			

*NOTE : Specifications are subject to change for quality improvement.

>> Features

1. Saving installation space by compact design of the machine
2. Fast & effective shot-blasting possible
3. Great efficient shot-blasting by powerful impeller
4. Installation without pit



>> Specifications

MODEL	KSB-1050
Material	H-BEAM & I-BEAM
Capacity	H-1,000×500×12,000mm
Purpose	De-scaling
Processing speed	Min. 1 ~ Max. 3m/min
Processing quality	SIS, B Sa2½ (at standard speed)
Impeller unit	6set (Ø270×10HP)
Dimension(W×L×H)	3,500×4,000×5,000mm

*NOTE : Specifications are subject to change for quality improvement.

B-H ASSEMBLING MACHINE

B-H STRAIGHTENING MACHINE

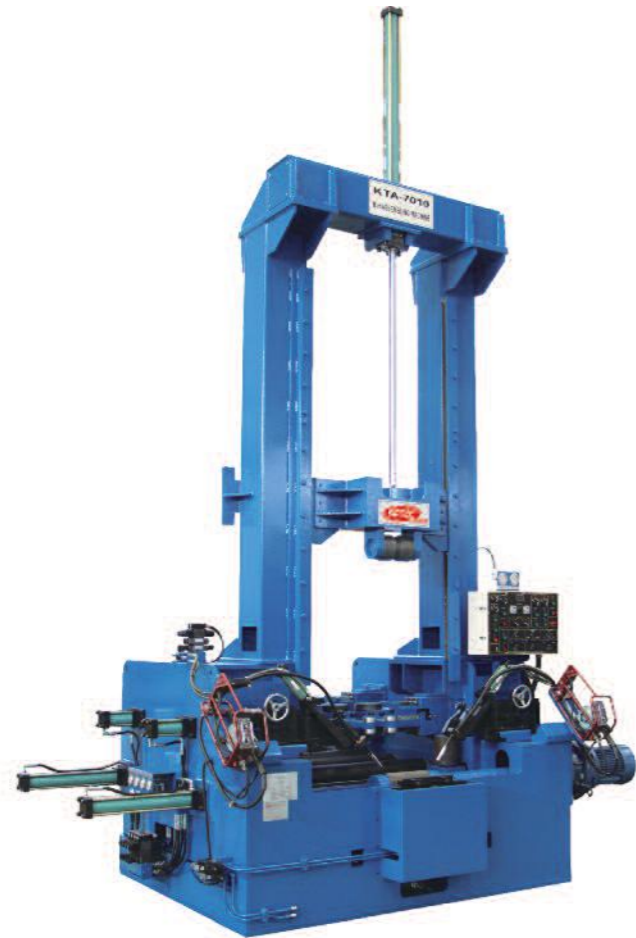

Model : KTA-7010

Welding H-Beam straightening machine

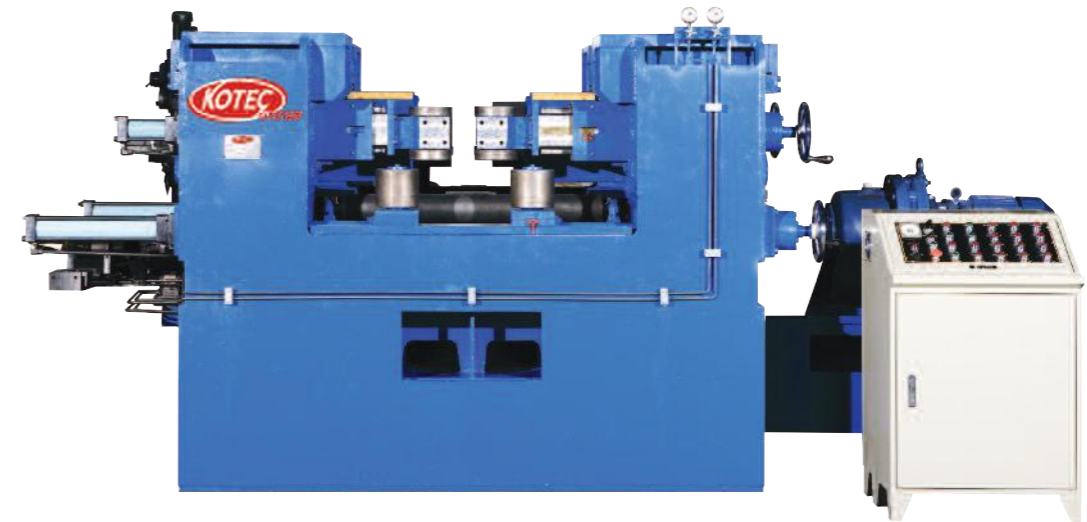

>> Features

1. H-Beam assembling, PEB / Camber beam option
2. Simple beam adjustment and operation
3. Tack welding / Full welding selectable



Tack welding

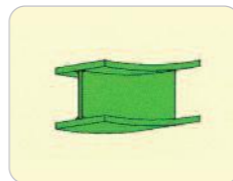

Camber beam(option)

>> Specifications

MODEL	KTA-7010	KTA-4060
Flange capacity	Max. 1,000mm×70t	Max. 600mm×45t
	Min. 200mm×16t	Min. 200mm×12t
Web capacity	2,000mm (Standard)	1,500mm (Standard)
	Min. 312mm	Min. 300mm
Co2 welding source	600A(2set)	
Dimension(W×L×H)	3,700×1,950×5,500mm	3,115×2,285×5,532mm
Weight	13,000kg	7,800kg

*NOTE : Specifications are subject to change for quality improvement.

>> Features

1. Deformed flange straightening
2. Designed for durable operation
3. Fast operation, increased productivity

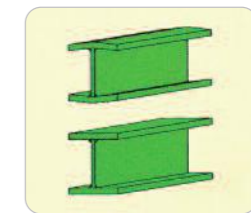

Flange de-warping

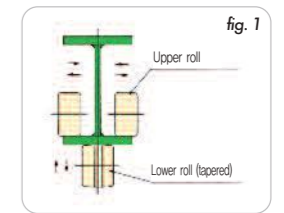

>> Specifications

MODEL	KTS-7010	KTS-4060
Flange capacity	Max. 1,000mm×70t	Max. 600mm×45t
	Min. 200mm×16t	Min. 200mm×12t
Web capacity	Min. 312mm	Min. 300mm
Straightening speed	8m/min	6.5m/min
Straightening power	120ton	100ton
Dimension(W×L×H)	4,500×1,850×1,900mm	3,115×2,285×1,500mm
Weight	13,000kg	8,000kg

*NOTE : Specifications are subject to change for quality improvement.

B-H ASSEMBLING & STRAIGHTENING MACHINE

SUBMERGED ARC WELDING MACHINE



>> Features

1. Combined machine for labor cost & saving space
2. H-Beam assembling + Straightening operation
PEB camber beam - optional
3. Submerged arc welding(SAW) - optional

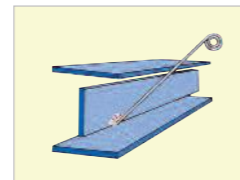

Tack welding

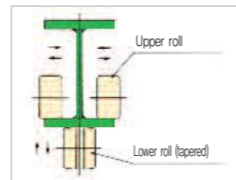

Straightening

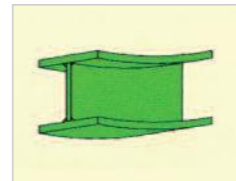

Camber beam(option)

>> Specifications

MODEL		KTAS-7010	KTAS-4060
Flange capacity	Assembly	Max. 1,000mm×70t	Max. 600mm×45t
	Straight	Max. 1,000mm×70t	Max. 600mm×45t
Web capacity	Standard	2,000mm	1,500mm
		Min. 312mm	Min. 300mm
CO ₂ welding source	600A(2set)		
Straightening speed	8m/min		6.5m/min
Straightening power	120ton		100ton
Dimension(W×L×H)	4,500×2,250×5,700mm		3,115×2,285×5,532mm
Weight	16,000kg		10,000kg

*NOTE : Specifications are subject to change for quality improvement.



25CT



2000WDS



>> Features

1. Optimized for heavy material manufacturing
2. Use of high-quality materials (EGI plate)

>> Specifications

MODEL	Input Volt	Input Capacity	No load Volt	Output Current	Output Volt	Duty Cycle	Dimension	Weight
1000WDS	220V/380V/440V	80KVA	82V	300~1000A	12~48V	80% @ Rated Output	75×1100×1150mm	415kg
1500WDS		120KVA	82V	300~1500A	18~52V		800×1050×1400mm	700kg
2000WDS		160KVA	82V	300~2000A	18~52V		800×1050×1400mm	720kg

*NOTE : Specifications are subject to change for quality improvement.

AUTO WELDING MACHINE

Gantry Type

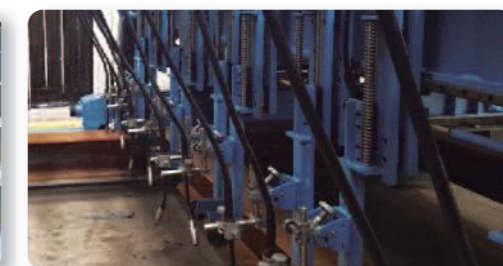
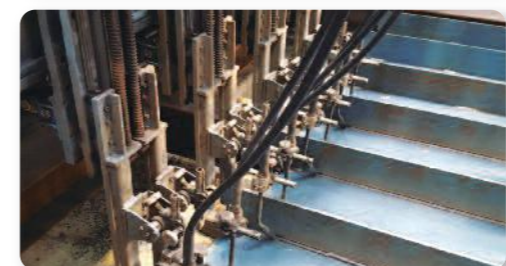

>> Features

1. Available for H-beam, Box-beam, PEB-beam, Camber beam
2. Automatic welding system for various beam